

HDPE GOLF IRRIGATION PRODUCT CATALOG

KIRCHDORFER IRRIGATION SYSTEM

HDPE PIPING SOLUTIONS • TECHNICAL EXPERTISE • FUSION EQUIPMENT





TABLE OF CONTENTS



Why Choose ISCO?	3
Golf Course Irrigation Systems	3
Benefits of HDPE	4
Operator Training	5
25-Year Limited Warranty	6
KIS HDPE	7
KIS HDPE Ball Valves	11
KIS Gate Valves	13
KIS HDPE Fittings	14
Specification Guide	35



Greetings,

In 1962, my father founded Kirhdorfer Irrigation out of the back of his father's neighborhood hardware store. His niche of providing irrigation systems to golf courses throughout the southeast grew significantly over time and the Kirhdorfer name became synonymous with quality, service, and innovation.

Our business has evolved since to serve various end markets and eventually became ISCO Industries. But still, our roots in golf course irrigation run deep. We're proud to carry out our legacy, offering custom fabricated pipe and fittings, but we're much more than the products we manufacture and sell.

ISCO's Kirhdorfer Irrigation System (KIS) is supported by hundreds of skilled professionals nationwide, dedicated to providing exceptional customer service. We assure you no company will work harder to earn your business and provide you with products and services to make your project a success.

Thank you for this opportunity for your business. We look forward to serving you.

Best,



Jimmy Kirhdorfer
CEO- ISCO Industries

INDUSTRY PARTNERS/AFFILIATIONS



WHY CHOOSE ISCO?

With 60 years of golf irrigation experience, customers depend on us for a solution that stands up to the pressure. This includes **high-density polyethylene (HDPE) pipe and fittings, fusion equipment, fabrication, on-site technical support, and training.** We offer a unique combination of customized solutions that assure successful project outcomes.



- **Single source** for pipe, fittings, training, technical expertise and assistance
- Innovator of **HDPE piping systems** for a wide variety of applications and industries such as golf, natural gas, nuclear, power, water, sewer, and landfill
- **McElroy-certified** fusion equipment mechanics, technicians and trainers
- Largest HDPE distributor with project materials **in-stock and available** across more than 35 locations in the U.S. and Canada
- **Experienced exporter of HDPE**, having serviced projects in more than 40 countries
- **25-year limited warranty**
- Access to **Fusion Hotline** staffed by trained McElroy mechanics and technicians
- **ISO9001:2015 certified**

GOLF COURSE IRRIGATION SYSTEMS

Golf irrigation systems need maximum reliability to achieve optimal course aesthetics, functionality and overall water quality. Using the right materials, equipment, and installation techniques, a new system will **stand up against pressure surges, water hammer effects, corrosion, soil conditions, environmental circumstances, and even seismic activity.**

With a tailored design and specification of correct equipment, your irrigation system should be more efficient, perform better and be more reliable—extending the life of the system and eliminating cost and time for repairs.

BENEFITS OF HDPE



Superior Strength and Flexibility

HDPE pipe can be bent to relatively severe angles without damage—reducing the need for fittings, thrust blocks, and restraints for directional changes.



Extreme Durability

Due to its strength and flexibility, the service life of HDPE pipe is estimated between 50 to 100 years depending on design, installation, and application.



The Green Solution

Recognized for their minimal impact on the environment, HDPE pipes are 100 percent recyclable and non-toxic.



Leak-Free

HDPE pipe is leak-free when produced properly, even at joints, which can be as strong and leak-free as the pipe itself through the heat fusion joining technique.



Corrosion, Deposit and Abrasion Resistance

Corrosion and chemical resistant, HDPE pipe does not rust, rot, pit, corrode, or support biological growth.



High Impact Resistance

HDPE offers seismic resistance and loading due to its natural flexibility, and can safely accommodate repetitive pressure surges.



Easier Installation

HDPE pipe is easier and more cost-efficient to install compared to other piping options on the market.

KIS HDPE SERVICES

Operator Training

Description:

Experienced, highly trained Field Fusion Technicians available for on-site training on the latest advancements and proper fusion techniques. Technicians will train on-site, virtually, as well as conduct demonstrations as requested by the customer.



Benefits:

- Our field technicians are experienced and factory qualified, holding McElroy fusion training and certifications
- Fusion Hotline: HDPE experts on call, staffed by trained McElroy mechanics and technicians
- Training conducted by the most highly qualified trainers in the industry

Fusion Machines

Whatever the project, whatever the need, ISCO has the HDPE fusion equipment and expertise to deliver the right solution.

ISCO is the industry leader in high density polyethylene (HDPE) piping solutions. With our strong North American presence, machine inventory and expertise, we can get you exactly what you need, whenever and wherever you need it.

Rent, buy used or buy new. As North America's largest distributor of McElroy HDPE fusion machines, ISCO is your best source, whether your preference is rental or purchase.

Largest and newest rental fleet in the industry. ISCO maintains the industry's largest and newest rental fleet. That means we have exactly the fusion machine you need, in great condition and ready to go to work.

More than HDPE fusion machines. Total HDPE solutions. The right machine, along with the right pipe, fittings and fabrications. Provided with advice and training to make sure your project goes smoothly.

We excel at solving problems. Our fusion machine selection and expertise are second to none. Equally important is our attitude. We live to solve problems. Count on ISCO for customized, on-the-money solutions.





KIS 25-Year Limited Warranty

Description:

ISCO's Kirchdorfer Irrigation Systems (KIS) comes with peace of mind through our 25-year limited warranty* against manufacturing defects and our comprehensive training services. All HDPE components of a complete KIS golf irrigation system carry our 25-year limited warranty.

Basic Specifications:

*ISCO Industries warrants that, for a period of twenty-five years from the date of shipment, ISCO will replace any section of HDPE pipe, fitting, and/or valve product installed for the Project that is defective in materials or workmanship, provided that Buyer, upon delivery of a defect, promptly notifies ISCO of the defect and, as instructed by ISCO at such time, either returns the product to ISCO for inspection or allows ISCO to inspect at the place of installation.

If the product is determined to be defective, ISCO will provide new product of the same specification and same quality as the defective product and ISCO will bear the expense of freight to deliver the replacement product to the job site. ISCO does not warrant the installation of any product. Any defects introduced after the shipment of product by ISCO, whether due to handling, installation or other cause, are not covered by this warranty. This warranty does not cover labor or other cost of installing products. Buyer's sole remedy for defective product shall be to receive replacement product as provided in this limited warranty. Products found to be unsatisfactory in performance will not be considered for coverage under the terms of this warranty if no documented pressure testing was performed at the time of installation.



Scan the QR code above or visit
www.isco-pipe.com/golf
to view the Golf Irrigation Specification Guide.

KIS HDPE PIPE



KIS High-Density Polyethylene Pipe (HDPE)

High density polyethylene (HDPE) pipe is an exceptional piping product well-suited for a broad range of demanding applications. Tough, resilient HDPE piping is widely used in municipal water and sewer applications, natural gas distribution, industrial process piping, fire water loops, mining/slurry handling systems and many more types of systems. With its strong, butt-fused joints and long-term ductility, HDPE pipe can be installed in numerous ways such as direct burial, slip-lining, pipe-bursting, and directional drilling. As a leading global distributor of HDPE piping systems and fusion equipment, along with fusion and fabrication services, ISCO Industries is your primary resource for all of your HDPE piping needs.

Important Standards for High Density Polyethylene (HDPE) Pipe

As with any engineering material, there are numerous standards and codes by which HDPE pipe and fittings are produced, designed and installed. Principle among these are the applicable standards published by ASTM International (formerly known as the American Society for Testing and Materials). Other additional standards and/or codes such as AWWA, DOT, API or others may apply to specific installations or uses of HDPE pipe as well. What follows is a partial listing of some of the principle standards pertaining to HDPE piping within the North American market area.

PIPE RESIN STANDARDS

ASTM D3350 - "Standard Specification for Polyethylene Plastics Pipe and Fitting Materials".

The quality of HDPE pipe starts with the resin from which it is produced. ASTM D3350 defines the basic physical property requirements of the polyethylene compound that is used to make the pipe or fittings.

PIPE DIMENSIONS AND MANUFACTURING STANDARDS

ASTM F714 - "Standard Specification for Polyethylene (PE) Pipe (SDR-PR) Based on Outside Diameter".

Pipe produced in accordance with this standard is used across a broad variety of municipal, industrial, and various water-related applications. This standard includes IPS, DIPS and metric sizing systems in nominal outside diameters from 3" - 54".

ASTM D2513 - "Standard Specification for Thermoplastic Gas Pressure Pipe, Tubing and Fittings".

Polyethylene pipe and other plastics for natural gas distribution are described in great detail in this standard.

ASTM D3035 - "Standard Specification for Polyethylene (PE) Plastic Pipe (DR-PR) Based on Controlled Outside Diameter".

Most HDPE water tubing (½" to 3") is made to the dimensions in this standard. This standard was revised to include IPS sizes up through nominal 65" outside diameter and DIPS sizes up through nominal 48" outside diameter for municipally oriented PE pipe applications or services.

ASTM F2619 - "Standard Specification for High Density Polyethylene (PE) Line Pipe".

This standard includes HDPE pipe in sizes from ½" to 65" for various oil and gas producing applications such as oil, dry or wet gas, multiphase fluids and non-potable oil field water.

ASTM F3123 - "Standard Specification for Metric Outside Diameter Polyethylene (PE) Plastic Pipe (DR-PN)".

INSTALLATION STANDARDS

ASTM D2321 - "Standard Practice for Underground Installation of Thermoplastic Pipe for Sewers and Other Gravity Flow Applications"

ASTM D2774 - "Standard Practice for Underground Installation of Thermoplastic Pressure Piping"

ASTM F585 - "Standard Practice for Insertion of Flexible Polyethylene Pipe into Existing Sewers"

ASTM F1668 - "Standard Guide for Construction Practices for Buried Plastic Pipe"

ASTM F1962 - "Standard Guide for Use of Maxi-Horizontal Directional Drilling for Placement of Polyethylene Pipe or Conduit Under Obstacles, Including River Crossings"

ASTM F2164 - "Standard Practice for Field Leak Testing of Polyethylene (PE) Pressure Piping Systems Using Hydrostatic Pressure".

AMERICAN WATER WORKS ASSOCIATION STANDARDS

ANSI/AWWA C901 - "Polyethylene Pressure Pipe and Tubing, .5 in. (13 mm) Through 3 in. (76 mm) for Water Service"

ANSI/AWWA C906 - "Polyethylene Pipe and Fittings, 4 in. (100 mm) through 63 in. (1,575 mm) for Water Distribution"

PIPE JOINING STANDARDS

ASTM F2620 - "Standard Practice for Heat Fusion of Polyethylene Pipe and Fittings"

ASTM D2657 - "Standard Practice of Heat Fusion Joining of Polyolefin Pipe and Fittings"

ASTM F1290 - "Standard Practice for Electrofusion Joining Polyolefin Pipe and Fittings"

FITTING STANDARDS

ASTM D3261 - "Standard Specification for Butt Heat Fusion Polyethylene (PE) Plastic Fittings for Polyethylene (PE) Plastic Pipe and Tubing"

ASTM F1055 - "Standard Specification for Electrofusion Fittings for Outside Diameter Controlled Polyethylene Pipe and Tubing"

ASTM F1759 - "Standard Practice for Design of High Density Polyethylene (HDPE) Manholes for Subsurface Applications"

ASTM F2206 - "Standard Specification for Fabricated Fittings of Butt-Fused Polyethylene (PE) Plastic Pipe, Fittings, Sheet Stock, Plate Stock or Block Stock"

ASTM F2880 - "Standard Specification for Lap-Joint Type Flange Adapters for Polyethylene Pressure Pipe in Nominal Pipe Sizes 3/4 in. to 65 in."

CANADIAN STANDARDS ASSOCIATION

CAN/CSA137 - "Thermoplastic Pressure Piping Compendium"

OTHER USEFUL REFERENCES

Handbook of Polyethylene Pipe, A publication of the Plastics Pipe Institute (www.plasticpipe.org)

AWWA M55, PE Pipe - Design and Installation, A Manual of Water Supply Practices published by the American Water Works Association

>>> See page 34 for HDPE pipe specifications.

4710 HDPE PIPE SIZES - IPS

DR	9	11	13.5	17
PE4710 Pressure Rating	250 psi	200 psi	160 psi	125 psi

Product No.	Description	Actual OD	Min Wall (in)	Avg ID (in)	Weight (lb/ft)
10021116	2" DR 11 IPS PIPE HDPE NSF D3035	2.375	0.216	1.917	0.642
10021123	2" DR 11 IPS 500' COILS HDPE NSF	2.375	0.216	1.917	0.642
10021120	2" DR 11 IPS 2000' COILS PIPE HDPE NSF	2.375	0.216	1.917	0.642
10021315	2" DR 13.5 IPS PIPE HDPE NSF	2.375	0.176	2.002	0.534
10021310	2" DR 13.5 IPS 500' COILS HDPE	2.375	0.176	2.002	0.534
10021318	2" DR 13.5 IPS PIPE 2000' COILS HDPE	2.375	0.176	2.002	0.534
10031118	3" DR 11 IPS PIPE HDPE NSF	3.5	0.318	2.825	1.395
10031119	3" DR 11 IPS 500' COILS PIPE HDPE NSF	3.5	0.318	2.825	1.395
10031311	3" DR 13.5 IPS PIPE HDPE NSF	3.5	0.259	2.95	1.16
10031313	3" DR 13.5 IPS 500' COILS NSF	3.5	0.259	2.95	1.16
10041121	4" DR 11 IPS PIPE HDPE AWWA	4.5	0.409	3.633	2.31
10041312	4" DR 13.5 IPS PIPE HDPE AWWA	4.5	0.333	3.793	1.92
10061122	6" DR 11 IPS PIPE HDPE AWWA	6.625	0.602	5.348	4.93
10061314	6" DR 13.5 IPS PIPE HDPE AWWA	6.625	0.491	5.585	4.152
10081122	8" DR 11 IPS PIPE HDPE AWWA	8.625	0.784	6.963	8.47
10081314	8" DR 13.5 IPS PIPE HDPE AWWA	8.625	0.639	7.271	7.04
10101117	10" DR 11 IPS PIPE HDPE AWWA	10.75	0.977	8.678	13.16
10101313	10" DR 13.5 IPS PIPE HDPE AWWA	10.75	0.796	9.062	10.932
10121118	12" DR 11 IPS PIPE HDPE AWWA	12.75	1.159	10.293	18.51
10121311	12" DR 13.5 IPS PIPE HDPE AWWA	12.75	0.944	10.748	15.38
10141116	14" DR 11 IPS PIPE HDPE AWWA	14	1.273	11.302	22.32
10141310	14" DR 13.5 IPS PIPE HDPE AWWA	14	1.037	11.801	18.54
10161115	16" DR 11 IPS PIPE HDPE AWWA	16	1.455	12.916	29.15
10161313	16" DR 13.5 IPS PIPE HDPE AWWA	16	1.185	13.487	24.22

1. Pressures are based on using water at 23°C (73°F).
2. Average inside diameter calculated using actual OD and minimum wall plus 6% for use in estimating fluid flows. Actual ID will vary.
3. Other piping sizes or DR's may be available upon request.
4. Standard Lengths:
 - 40' for 2"-24"
 - 50' for 26" and larger
 - Coils available for ¾ - 4" (6" by special order)
5. More sizes & DRs available upon request.

KIS HDPE Quarter Turn Ball Valves

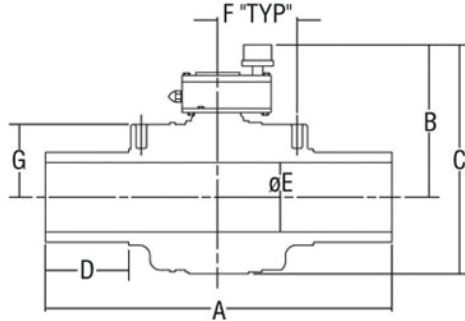

Description:

These ball valves have a quarter-degree turn for easy open and close functionality. Fully operated from open to close by key while under working pressure.

Benefits:

- Durable, drop-tight, shut-off, fused-body shell
- No metal internal parts, rust-free, eliminating corrosion
- Part of a full, leak-free HDPE system
- Uninhibited full-bore design for unrestricted flow, maximum capacity and performance
- NSF certified for use in potable water systems

Product No.	Description	A	B	C	D	E	Weight (kg)
KIS02001	2" FULL PORT HDPE WATER BALL VALVE FOR KIS ONLY BALL VALVE	14.7	6.4	9.1	4.2	1.82	3.8
KIS03001	3" FULL PORT HDPE WATER BALL VALVE FOR KIS ONLY	15.0	8.0	11.4	3.5	2.50	8.9

**Larger sizes available upon request.*

KIS HDPE 360° Ball Valves



Description:

KIS 360° Ball Valves have a full port 360 degree gear turn to open and close. Fully operated from open to close by hand while under full-rate working pressure.

Benefits:

- Valve can be opened and closed by hand while under fully-rated working pressure
- Can be connected via butt fusion, socket fusion or electrofusion
- Protects swing joints and sprinklers by preventing lateral line water hammer
- Unique stem design eliminates over torquing and stem breakage
- Clear visual indicator shows the working positions: Open/Throttle/Close

Design/Testing:

- PE4710 & PE100 resin
- ANSI/NSF 61, ASME B16.40, AWWA C901 & C906
- Operating pressure of 200 PSI

PART	MATERIAL
BODY	Polyethylene
END	Polyethylene
BALL	Polypropylene
BALL SEAT	Nitrile
P.G. OPERATOR	Acetal (POM)
STEM	Acetal (POM)
WEATHER SEAL	Nitrile
STEM SEAL	Nitrile
RETAINER	Polypropylene

Product No.	Description	Weight (lbs)
KIS02002	2" DR 11 IPS 360 KIS HDPE WATER BALL VALVE	4.19
KIS03002	3" DR 11 IPS 360 KIS HDPE WATER BALL VALVE	8.60



KIS Gate Valves

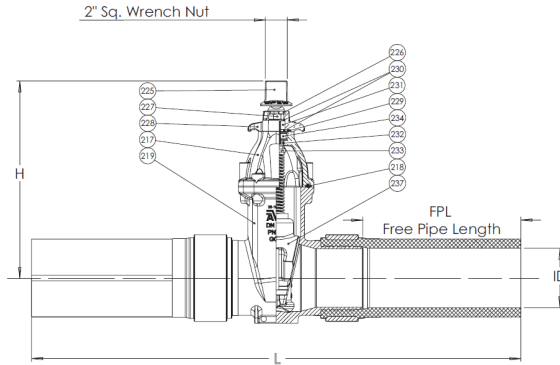

Description:

Lightweight and resilient seated gate valves feature a watertight design made exclusively for HDPE pipe systems. HDPE ends offer corrosion resistance and non-leaking properties.

Benefits:

- Resilient seated design with AWWA 2" square operating nut. Stainless steel ASTM A582 stem.
- The valve-to-pipe joint is watertight and stronger than the pipe itself and meets AWWA C515 standards. FM approved in IPS only.
- Self-restrained, which eliminates the need for thrust blocking
- Available with HDPE ends, flanged, or mechanical joint connections upon request

Product No.	Description	H	L	Free Pipe Length (FPL)	Turns to open	Weight (lbs.)
59021116	2" DR 11 IPS AVK PE GATE VALVE SERIES 66	10.50"	19.50"	5.10"	11	20
59031110	3" DR 11 IPS AVK PE GATE VALVE SERIES 66	12.09"	19.75"	5.20"	12	36
59041110	4" DR 11 IPS AVK PE GATE VALVE SERIES 66	13.50"	41.93"	14.92"	14	56
59061110	6" DR 11 IPS AVK PE GATE VALVE SERIES 66	17.50"	43.35"	14.00"	21	114
59081110	8" DR 11 IPS AVK PE GATE VALVE SERIES 66	21.50"	44.06"	13.04"	26	175
59101110	10" DR 11 IPS AVK PE GATE VALVE SERIES 66	24.75"	44.96"	11.25"	32	227
59121110	12" DR 11 IPS AVK PE GATE VALVE SERIES 66	27.63"	47.09"	11.14"	38	335

**Larger sizes available upon request.*

KIS HDPE Fittings

HDPE Fittings - Molded

There are two basic methods of creating most HDPE fittings, either by injection molding or fabricating from pipe or cylinders. Molded fittings are typically fully pressure rated, since the body of the molded fitting is reinforced with extra material around the OD at the bend, branch, or reduction to provide additional strength and maintain the intended pressure rating. The reinforcement terminates near the end of the molded fitting so that it has the same outside diameter of the pipe to facilitate welding. Fittings that are typically made by injection molding are 90 degree elbows, 45 degree elbows, tees, reducers, end caps and flange adapters. Molded fittings are typically available in 12" and smaller sizes due to processing and cost variables.



HDPE Fittings - Fabricated

Like any other material, HDPE fabricated elbows and tees have a reduced pressure rating because the miter cut and weld create an effective oval at the welded intersection. Stress is increased during operation because of changes in flow direction. As the angle of the miter cut increases, the operating stress also increases along with the challenge of maintaining section alignment. Sweep bends that are forged from pipe have no cuts/welds, therefore have no derating.

In the early stages of the HDPE industry, a standard 25% derating for HDPE elbows was commonly used. With the advent of elbows made with larger miter angles (i.e. 3 segment 90/2 segment 45) and new resins, a more systematic approach was needed. The American Society of Mechanical Engineers offered an equation within the process piping code B31.3 that was incorporated by ISCO from 2003 to 2016. In section 304.2, equations 4a and 4b were used to determine pressure ratings of mitered elbows. For HDPE fittings, the pressure rating at that time was based on three criteria: the miter angle, the resin's material properties (Pipe Design Stress), and the wall thickness.



ISCO has taken the next step in the advancement of producing high-quality fabricated HDPE fittings. Our fabricated elbows, tees, reducing tees, and end caps are now produced and tested in accordance with ASTM F2206 - "Standard Specification for Fabricated Fittings of Butt-Fused Polyethylene Plastic Pipe". ASTM F2206 places very specific requirements on fabricated fittings in two areas - the type of HDPE pipe, fittings, and plate or sheet stock used in the manufacturing of pressure-rated fabricated fittings; and the testing required for qualifying fabricated fittings.

Piping System DR	Feedstock DR	Fitting EDR	Fitting Pressure Rating (psi)
7	5	7	335
9	7	9	250
11	9	11	200
13.5	11	13.5	160
17	11	17	125
21	17	21	100
26	21	26	80
32.5	26	32.5	63

ISCO only uses PE4710 HDPE materials per ASTM D3350 and HDPE pipe manufactured in accordance with ASTM D3035, ASTM F714, or ASTM F2619 to produce ASTM F2206 fabricated fittings. In addition, ISCO has contracted with accredited third-party agencies to conduct the short-term and elevated-temperature sustained-pressure proof-of-design testing required to meet the ASTM F2206 standard.

ASTM F2206 also establishes the concept of Equivalent Dimension Ratio, or EDR, that simplifies the process of matching the required pressure rating of fabricated fittings using miter cut feedstock (elbows and straight line tees) to that of the pipe in which it will be joined. EDRs are determined for each fitting type and wall thickness by the collection of empirical data from the required ASTM F2206 pressure testing (see Table 6a and 6b for testing information). The EDR methodology provides HDPE piping system designers with a consistent means for specifying HDPE fabricated fittings. Note: Standard ISCO ASTM F2206 fabricated fittings are not manufactured with beveled ends on the inside diameter; however, this option is available upon request.

ISCO has not included HDPE fabricated crosses and lateral wyes within the ASTM F2206 offering. ISCO recommends that engineers considering the use of HDPE crosses and lateral wyes implement derating factors.

The chart below is representative of a pressure chart for each fitting page, where items in bold blue are considered standard in many sizes. Those in gray are considered non-standard and availability may be limited. Those not listed are not available for that fitting style.

Feedstock DR	32.5	26	21	17	13.5	11	9	7
Pressure Rating	XX psi	XX psi	XX psi	XX psi	XX psi	XX psi	XX psi	XX psi
EDR	XX	XX	XX	XX	XX	XX	XX	XX

Range of PE Wall Thickness Fusion Compatibility

Pipe or Fitting DR	Can be fused to a pipe or fitting with a		
	Min DR of	or	Max DR of
7	5.5		9
9	7		11
11	9		13.5
13.5	11		17
17	13.5		21
21	17		26
26	21		32.5
32.5	26		41

Basic Specifications:

ASTM F 2620 - ISCO recommends following the accepted industry practice that the wall thickness difference should not exceed 26% in order to maintain the pressure rating of the lowest rated component (the thinner of the two wall thicknesses) involved in the butt fusion. Wall thickness differences in excess of this recommendation may induce a stress riser that could affect the quality of fusion joint to withstand events like pressure surges and external loading that may not affect welds with the same wall thickness. Example: Pipe or fittings that have a wall thickness of 1" would be welded to a pipe or fitting with a wall thickness of .74" or 1.35" to maintain full pressure rating.



KIS 90° Elbow Molded

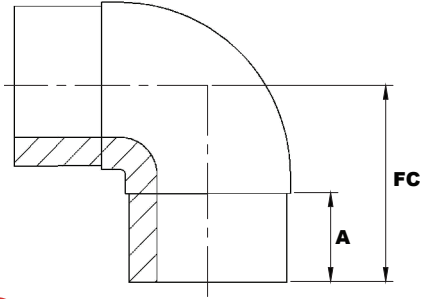

DR	17	11	9	7
Pressure Rating	125 psi	200 psi	250 psi	333 psi

Product No.	Description	OD (in)	A (in)	FC (in)
50021117	2" DR 11 IPS 90 DEG ELBOW MOLDED	2.375	2.54	4.68
50031114	3" DR 11 IPS 90 DEG ELBOW MOLDED	3.5	3.16	6.75
50041121	4" DR 11 IPS 90 DEG ELBOW MOLDED	4.5	3.875	6.38
50061124	6" DR 11 IPS 90 DEG ELBOW MOLDED	6.625	4.5	8.63
50081123	8" DR 11 IPS 90 DEG ELBOW MOLDED	8.625	6.1	11.1
50101113	10" DR 11 IPS 90 DEG ELBOW MOLDED	10.75	6	13.25
5012114	12" DR 11 IPS 90 DEG ELBOW MOLDED	12.75	8	15.25

DID YOU KNOW?

In 2012, ISCO's founder, Jim Kirchdorfer Sr., was the recipient of the Golf Course Builders Association of America (GCBA) Don A. Rossi Award, which is presented to "an individual who has made a significant contribution to the game of golf and its growth." Today, his sons and ISCO are proud to carry on the legacy of involvement with this great sport.



KIS 90° Elbow Fabricated Three-Segment Mitered Bend

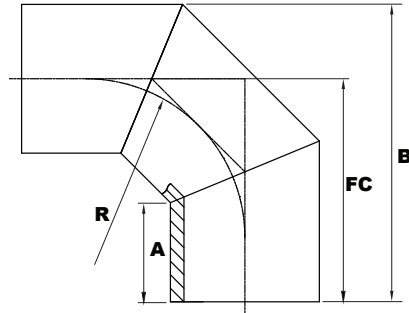

Feedstock DR	17	13.5	11	9	7
Pressure Rating	100 psi	125 psi	160 psi	200 psi	250 psi
EDR	21	17	13.5	11	9

Product No.	Description	OD (in)	A (in)	B (in)	FC (in)	R (in)
40081113	8" DR 11 IPS 90 DEG ELBOW 3-SEG FAB HDPE EDR 13.5	8.625	6.5	19.7212	15.4087	12.1587
40101112	10" DR 11 IPS 90 DEG ELBOW 3-SEG FAB HDPE EDR 13.5	10.75	6.5	21.4926	16.1176	12.6176
40121112	12" DR 11 IPS 90 DEG ELBOW 3-SEG FAB HDPE EDR 13.5	12.75	8.5	25.4926	19.1176	13.6176
40141159	14" DR 11 IPS 90 DEG ELBOW 3-SEG FAB HDPE EDR 13.5	14	8.5	26.7426	19.7426	14.2426
40161112	16" DR 11 IPS 90 DEG ELBOW 3-SEG FAB HDPE EDR 13.5	16	8.5	29.4497	21.4497	16.4497

1. Elbows other than 90° and 45° are available as an FM Approved fabricated fitting. Contact your ISCO representative for availability and dimensions.
2. EDR (Equivalent Dimensional Ratio) - The EDR is the DR of the piping system for which the fabricated fittings is intended to be butt fused.
3. Larger sizes available upon request.



KIS 90° Elbow Fabricated Five-Segment Mitered Bend

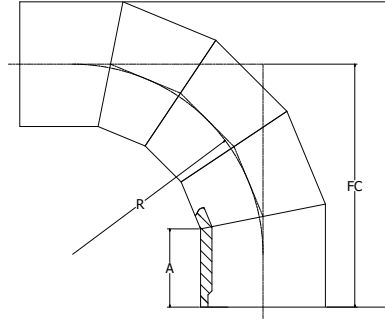

Feedstock DR	17	13.5	11	9	7
Pressure Rating	100 psi	125 psi	160 psi	200 psi	250 psi
EDR	21	17	13.5	11	9

Product No.	Description	OD (in)	A (in)	B (in)	FC (in)	R (in)
40081127	8" DR 11 IPS 90 DEG ELBOW 5-SEG FAB HDPE EDR 13.5	8.625	6.5	24.6899	20.3774	16.2524
40101128	10" DR 11 IPS 90 DEG ELBOW 5-SEG FAB HDPE EDR 13.5	10.75	6.5	26.8149	21.4399	17.3149
40121135	12" DR 11 IPS 90 DEG ELBOW 5-SEG FAB HDPE EDR 13.5	12.75	8	31.2211	24.8461	19.4461
40141131	14" DR 11 IPS 90 DEG ELBOW 5-SEG FAB HDPE EDR 13.5	14	8	33.2766	26.2766	21.0766
40161138	16" DR 11 IPS 90 DEG ELBOW 5-SEG FAB HDPE EDR 13.5	16	8	36.8875	28.8875	24.0875

1. Elbows other than 90° and 45° are available as an FM Approved fabricated fitting. Contact your ISCO representative for availability and dimensions.
2. EDR (Equivalent Dimensional Ratio) - The EDR is the DR of the piping system for which the fabricated fittings is intended to be butt fused.
3. Larger sizes available upon request.

KIS 45° Elbow Molded

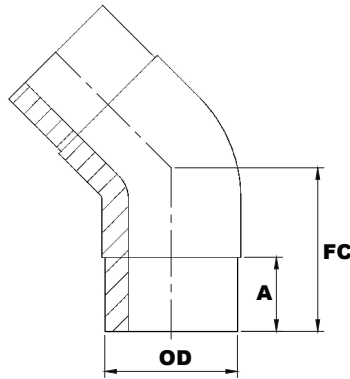

DR	17	11	9	7
Pressure Rating	125 psi	200 psi	250 psi	333 psi

Product No.	Description	OD (in)	A (in)	FC (in)
50021116	2" DR 11 IPS 45 DEG ELBOW MOLDED	2.375	2.45	3.5
50031113	3" DR 11 IPS 45 DEG ELBOW MOLDED	3.5	3.55	6
50041120	4" DR 11 IPS 45 DEG ELBOW MOLDED	4.5	3.75	6.25
50061123	6" DR 11 IPS 45 DEG ELBOW MOLDED	6.625	4.75	8.5
50081122	8" DR 11 IPS 45 DEG ELBOW MOLDED	8.625	6.55	9.75
50101112	10" DR 11 IPS 45 DEG ELBOW MOLDED	10.75	6.25	13.38
50121113	12" DR 11 IPS 45 DEG ELBOW MOLDED	12.75	8	15.75

1. Some size/DR combinations may have limited availability.
2. Other DRs available with counter-bored ID at fitting end.
3. Larger sizes available upon request.



TRAINING

We can provide experienced, factory-trained fusion technicians to accompany any purchased or leased machine for on-site training nationwide. These technicians are also OSHA compliant and Confined Space Certified.



KIS 45° Elbow Fabricated Two-Segment Mitered Bend

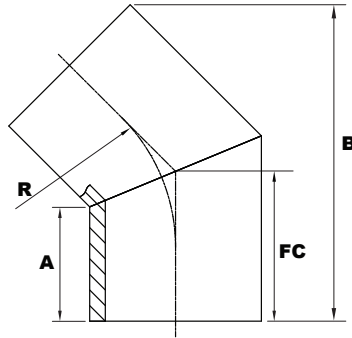

Feedstock DR	17	13.5	11	9	7
Pressure Rating	100 psi	125 psi	160 psi	200 psi	250 psi
EDR	21	17	13.5	11	9

Product No.	Description	OD (in)	A (in)	B (in)	FC (in)	R (in)
40081139	8" DR 11 IPS 45 DEG ELBOW 2-SEG FAB HDPE EDR 13.5	8.625	6.5	17.195	8.2863	12.1587
40101111	10" DR 11 IPS 45 DEG ELBOW 2-SEG FAB HDPE EDR 13.5	10.75	6.5	18.6976	8.7264	12.6176
40121105	12" DR 11 IPS 45 DEG ELBOW 2-SEG FAB HDPE EDR 13.5	12.75	8.5	23.526	11.1406	13.6176
40141110	14" DR 11 IPS 45 DEG ELBOW 2-SEG FAB HDPE EDR 13.5	14	8.5	24.4099	11.3995	14.2426
40161164	16" DR 11 IPS 45 DEG ELBOW 2-SEG FAB HDPE EDR 13.5	16	8.5	25.8241	11.8137	15.2426

1. Elbows other than 90° and 45° are available as an FM Approved fabricated fitting. Contact your ISCO representative for availability and dimensions.
2. EDR (Equivalent Dimensional Ratio) - The EDR is the DR of the piping system for which the fabricated fittings is intended to be butt fused.
3. Larger sizes available upon request.

KIS 45° Elbow Fabricated Three-Segment Mitered Bend

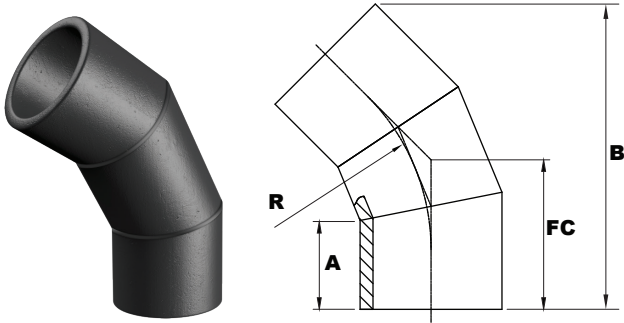

Feedstock DR	17	13.5	11	9	7
Pressure Rating	100 psi	125 psi	160 psi	200 psi	250 psi
EDR	21	17	13.5	11	9

Product No.	Description	OD (in)	A (in)	B (in)	FC (in)	R (in)
40081126	8" DR 11 IPS 45 DEG ELBOW 3-SEG FAB HDPE EDR 13.5	8.625	6.5	21.5834	10.857	16.2524
40101132	10" DR 11 IPS 45 DEG ELBOW 3-SEG FAB HDPE EDR 13.5	10.75	6.5	23.0860	11.2971	17.3149
40121133	12" DR 11 IPS 45 DEG ELBOW 3-SEG FAB HDPE EDR 13.5	12.75	8	27.4766	13.4548	19.4461
40141130	14" DR 11 IPS 45 DEG ELBOW 3-SEG FAB HDPE EDR 13.5	14	8	28.7301	13.9302	21.0766
40161137	16" DR 11 IPS 45 DEG ELBOW 3-SEG FAB HDPE EDR 13.5	16	8	30.8834	14.7774	24.0875

1. Elbows other than 90° and 45° are available as an FM Approved fabricated fitting. Contact your ISCO representative for availability and dimensions.
2. EDR (Equivalent Dimensional Ratio) - The EDR is the DR of the piping system for which the fabricated fittings is intended to be butt fused.
3. Larger sizes available upon request.

KIS 22.5° Elbow Fabricated Two-Segment Mitered Bend

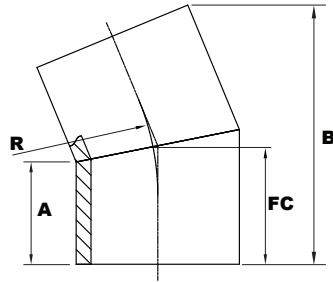

Feedstock DR	17	13.5	11	9	7
Pressure Rating	100 psi	125 psi	160 psi	200 psi	250 psi
EDR	21	17	13.5	11	9

Product No.	Description	OD (in)	A (in)	B (in)	FC (in)	R (in)
40021141	2" DR 11 IPS 22.5 DEG ELBOW 2-SEG FAB HDPE EDR 13.5	2.375	4	8.6044	4.2362	13.1274
40031112	3" DR 11 IPS 22.5 DEG ELBOW 2-SEG FAB HDPE EDR 13.5	3.5	4	9.0349	4.3481	13.6899
40041117	4" DR 11 IPS 22.5 DEG ELBOW 2-SEG FAB HDPE EDR 13.5	4.5	5	11.3415	5.4476	14.1899
40061118	6" DR 11 IPS 22.5 DEG ELBOW 2-SEG FAB HDPE EDR 13.5	6.625	6	14.0786	6.6589	15.2524
40081125	8" DR 11 IPS 22.5 DEG ELBOW 2-SEG FAB HDPE EDR 13.5	8.625	6.5	15.8059	7.3578	16.2524
40101126	10" DR 11 IPS 22.5 DEG ELBOW 2-SEG FAB HDPE EDR 13.5	10.75	6.5	16.6191	7.5692	17.3149
40121130	12" DR 11 IPS 22.5 DEG ELBOW 2-SEG FAB HDPE EDR 13.5	12.75	8	20.2703	9.2681	19.4461
40141129	14" DR 11 IPS 22.5 DEG ELBOW 2-SEG FAB HDPE EDR 13.5	14	8	20.7486	9.3924	21.0766
40161136	16" DR 11 IPS 22.5 DEG ELBOW 2-SEG FAB HDPE EDR 13.5	16	8	21.514	9.5913	24.0875

1. Elbows other than 90° and 45° are available as an FM Approved fabricated fitting. Contact your ISCO representative for availability and dimensions.
2. EDR (Equivalent Dimensional Ratio) - The EDR is the DR of the piping system for which the fabricated fittings is intended to be butt fused.
3. Larger sizes available upon request.

DID YOU KNOW?

ISCO Industries is an industry leader in quality, which is demonstrated by its unsurpassed credentials from third party certifying bodies. ISCO Industries is the only HDPE solution provider to carry these credentials from ISO and Factory Mutual.



Registered to ISO 9001

KIS Flange Adapter

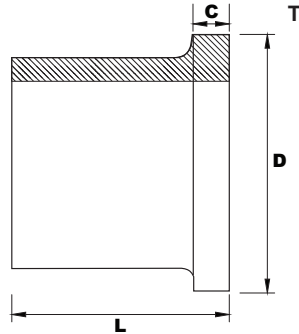

DR	17	13.5	11	9	7
Pressure Rating	125 psi	160 psi	200 psi	250 psi	333 psi

Product No.	Description	OD (in)	D (in)	L (in)	T (in)
50021115	2" DR 11 IPS FLANGE ADAPTER	2.375	4	6	0.45
50031112	3" DR 11 IPS FLANGE ADAPTER	3.5	5	6	0.67
50041119	4" DR 11 IPS FLANGE ADAPTER	4.5	6.598	6	0.896
50061122	6" DR 11 IPS FLANGE ADAPTER	6.625	8.5	8	0.895
50081121	8" DR 11 IPS FLANGE ADAPTER	8.625	10.598	9	1.12
50101117	10" DR 11 IPS FLANGE ADAPTER	10.75	12.799	10.75	1.455
50121119	12" DR 11 IPS FLANGE ADAPTER	12.75	15.252	11	1.725
50141114	14" DR 11 IPS FLANGE ADAPTER	14	17.5	11	1.905
50161113	16" DR 11 IPS FLANGE ADAPTER	16	20	12	2.13

*Other sizes and DRs available upon request



KIS Back Up Rings - Ductile Iron for use with Flange Adapter

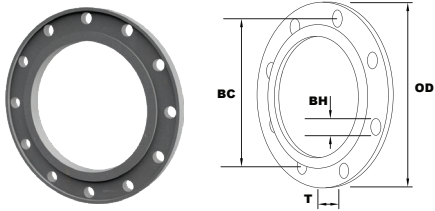

Product No.	Description	Pipe OD (in)	Pressure Rating (psi)	OD (in)	BC (in)	BH (in)	T (in)	Bolt #
53020022	2" DR 11 IPS BACKUP RING DUCTILE IRON	2.375	200	6	4.75	0.75	0.5	4
53030022	3" DR 11 IPS BACKUP RING DUCTILE IRON	3.5	200	7.5	6	0.75	0.53	4
53040024	4" DR 11 IPS BACKUP RING DUCTILE IRON	4.5	200	9	7.5	0.75	0.55	8
53060031	6" DR 11 IPS BACKUP RING DUCTILE IRON	6.625	200	11	9.5	0.875	0.63	8
53080032	8" DR 11 IPS BACKUP RING DUCTILE IRON	8.625	200	13.5	11.75	0.875	0.85	8
53100028	10" DR 11 IPS BACKUP RING DUCTILE IRON	10.75	200	16	14.25	1	0.98	12
53120030	12" DR 11 IPS BACKUP RING DUCTILE IRON	12.75	200	19	17	1	1.25	12

*Other sizes and DRs available upon request

*Standard surface treatment is painted primer. Optional surface treatments are available as galvanized, epoxy-coated, or powder-coated. Availabilities may be extended.

*Stainless steel available upon request

KIS Neoprene Gaskets - For use with Flange Adapter

Product No.	Description
53021018	2" NEOPRENE GASKET 1/8" THICK
53031017	3" NEOPRENE GASKET 1/8" THICK
53041018	4" NEOPRENE GASKET 1/8" THICK
53061016	6" NEOPRENE GASKET 1/8" THICK
53080076	8" NEOPRENE GASKET 1/8" THICK
53100048	10" NEOPRENE GASKET 1/8" THICK
53120046	12" NEOPRENE GASKET 1/8" THICK

KIS Boltpacks - For use with Flange Adapter

Product No.	Description
53021014	2" STD BOLTPACK MFA & BUR (4) 5/8" X 4" BOLT W/ NUT & WASH (ZN-PLATED)
53031011	3" STD BOLTPACK MFA & BUR (4) 5/8" X 5" BOLT W/ NUT & WASH (ZN-PLATED)
53041011	4" STD BOLTPACK MFA & BUR (8) 5/8" X 5 1/4" BOLT W/ NUT & WASH (ZN-PLATED)
53061012	6" STD BOLTPACK MFA & BUR (8) 3/4" X 5 1/7" BOLT W/ NUT & WASH (ZN-PLATED)
53080070	8" STD BOLTPACK MFA & BUR (8) 3/4" X 6 1/8" BOLT W/ NUT & WASH (ZN-PLATED)
53100045	10" STD BOLTPACK MFA & BUR (12) 7/8" X 7 3/4" BOLT W/ NUT & WASH (ZN-PLATED)
53120038	12" STD BOLTPACK MFA & BUR (12) 7/8" X 8 1/2" BOLT W/ NUT & WASH (ZN-PLATED)

**Boltpacks also available in stainless steel*

DID YOU KNOW?

ISCO's Fusion Manual provides step-by-step instruction on how to operate McElroy Fusion equipment. It's printed in both English and Spanish and comes on waterproof, tear-proof paper to last longer in the elements of field work.

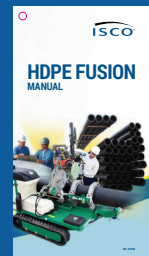



KIS Mechanical Joint Adapters

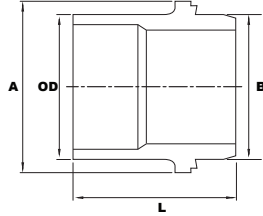
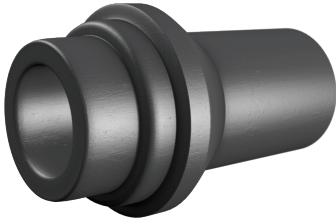

DR	17	11	9
Pressure Rating	125 psi	200 psi	250 psi

Product No.	Description	OD (in)	A (in)	B (in)	L (in)
53021135	2" DR 11 IPS MJ ADAPTER ONLY PE W/ SS STIFFENER	2.375	3.5	2.5	8
53031133	3" DR 11 IPS MJ ADAPTER ONLY PE W/ SS STIFFENER	3.5	5.37	3.96	8.5
53041138	4" DR 11 IPS MJ ADAPTER ONLY PE W/ SS STIFFENER	4.5	6.63	4.8	8
53061133	6" DR 11 IPS MJ ADAPTER ONLY PE W/ SS STIFFENER	6.625	8.63	6.9	9.5
53081129	8" DR 11 IPS MJ ADAPTER ONLY PE W/ SS STIFFENER	8.625	10.75	9.05	11.5
53101126	10" DR 11 IPS MJ ADAPTER ONLY PE W/ SS STIFFENER	10.75	12.75	11.1	13
53121125	12" DR 11 IPS MJ ADAPTER ONLY PE W/ SS STIFFENER	12.75	15.25	13.2	13.5

*MJ adapters are available without stiffener. Stiffener not required.

KIS Mechanical Joint Accessory Kits

Product No.	Description
53020074	2" ACCESSORY KIT C110 FOR MJ ADAPTER W/ GLAND, BOLTS, GASKET
53030056	3" ACCESSORY KIT C110 FOR MJ ADAPTER W/ GLAND, BOLTS, GASKET
53040073	4" ACCESSORY KIT C110 FOR MJ ADAPTER W/ GLAND, BOLTS, GASKET
53060081	6" ACCESSORY KIT C110 FOR MJ ADAPTER W/ GLAND, BOLTS, GASKET
53080093	8" ACCESSORY KIT C110 FOR MJ ADAPTER W/ GLAND, BOLTS, GASKET
53100063	10" ACCESSORY KIT C110 FOR MJ ADAPTER W/ GLAND, BOLTS, GASKET
53120059	12" ACCESSORY KIT C110 FOR MJ ADAPTER W/ GLAND, BOLTS, GASKET

*Accessory kits available in stainless steel and cor-blue upon request.

*C153 also available.

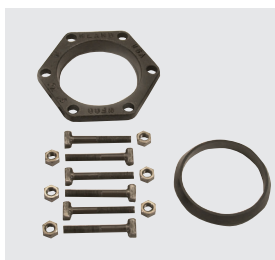

MJ ADAPTER KIT (sold separately)

Kit Includes:

- Gasket
- T-Bolts and Nuts
- Metal Gland:
 - Included in 12-inch and smaller sizes, available as C110 (heavyweight) or C153 (lightweight)
 - C110 Metal Gland sold separately for 14-inch and larger.

KIS Concentric Reducers

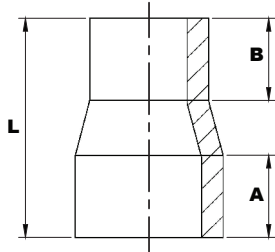

DR	17	11	9
Pressure Rating	125 psi	200 psi	250 psi

Product No.	Description	OD1 (in)	OD2 (in)	A (in)	B (in)	L (in)
50011117	1-1/2" X 1" DR 11 IPS CONCENTRIC REDUCER	1.9	1.315	3.7	1.35	6.35
50021125	2" X 1" DR 11 IPS CONCENTRIC REDUCER	2.375	1.315	3	1.525	6.15
50021122	2" X 1-1/2" DR 11 IPS CONCENTRIC REDUCER	2.375	1.9	3.125	2.8	7.2
50031122	3" X 2" DR 11 IPS CONCENTRIC REDUCER	3.5	2.375	3.25	2.63	7.15
50041129	4" X 2" DR 11 IPS CONCENTRIC REDUCER	4.5	2.375	3.38	2.75	7.88
50041132	4" X 3" DR 11 IPS CONCENTRIC REDUCER	4.5	3.5	3.38	3.25	7.88
50061132	6" X 3" DR 11 IPS CONCENTRIC REDUCER	6.625	3.5	5.06	3.78	11.18
50061136	6" X 4" DR 11 IPS CONCENTRIC REDUCER	6.625	4.5	4.38	3.75	9.25
40081133	8" X 4" DR 11 IPS CONCENTRIC REDUCER	8.625	4.5	4.65	3.55	11.425
50081138	8" X 6" DR 11 IPS CONCENTRIC REDUCER	8.625	6.625	5.06	4.88	11.75
40101137	10" X 6" DR 11 IPS CONCENTRIC REDUCER	10.75	6.625	6	6	12
50101126	10" X 8" DR 11 IPS CONCENTRIC REDUCER	10.75	8.625	6.5	6.5	15
50121135	12" X 8" DR 11 IPS CONCENTRIC REDUCER	12.75	8.625	6.65	6.55	15
50121121	12" X 10" DR 11 IPS CONCENTRIC REDUCER	12.75	10.75	6.5	6.5	15.25
40141135	14" X 10" DR 11 IPS CONCENTRIC REDUCER	14	10.75	7	7	14
40141137	14" X 12" DR 11 IPS CONCENTRIC REDUCER	14	12.75	7	7	14

*More sizes available upon request.



KIS Reducing Tees Molded

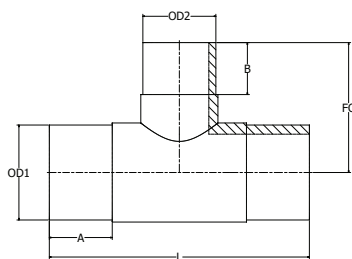

Product No.	Description	OD1 (in)	OD2 (in)	A (in)	B (in)	FC (in)	L (in)
50031138	3" X 2" DR 11 IPS REDUCING TEE MOLDED	3.5	2.375	3.62	2.48	5.9	11.8
50041156	4" X 2" DR 11 IPS REDUCING TEE MOLDED	4.5	2.375	3.94	2.48	6.89	13.78
50041160	4" X 3" DR 11 IPS REDUCING TEE MOLDED	4.5	3.5	3.94	3.62	6.89	13.78
50061168	6" X 2" DR 11 IPS REDUCING TEE MOLDED	6.625	2.375	4.72	2.48	9.06	18.1
50061169	6" X 3" DR 11 IPS REDUCING TEE MOLDED	6.625	3.5	4.72	3.62	9.06	18.1
50061166	6" X 4" DR 11 IPS REDUCING TEE MOLDED	6.625	4.5	4.72	3.94	9.06	18.1
50081173	8" X 3" DR 11 IPS REDUCING TEE MOLDED	8.625	3.5	5.71	3.62	11.8	23.6
50081168	8" X 4" DR 11 IPS REDUCING TEE MOLDED	8.625	4.5	5.71	3.94	11.8	23.6
50081169	8" X 6" DR 11 IPS REDUCING TEE MOLDED	8.625	6.625	5.71	4.72	11.8	23.6
50101149	10" X 4" DR 11 IPS REDUCING TEE MOLDED	10.75	4.5	6.3	3.94	13.78	27.4
50101150	10" X 6" DR 11 IPS REDUCING TEE MOLDED	10.75	6.625	6.3	4.72	13.78	27.4
50101151	10" X 8" DR 11 IPS REDUCING TEE MOLDED	10.75	8.625	6.3	5.71	13.78	27.4
50121173	12" X 6" DR 11 IPS REDUCING TEE MOLDED	12.75	6.625	7.48	4.72	15.95	31.4
50121172	12" X 8" DR 11 IPS REDUCING TEE MOLDED	12.75	8.625	7.48	5.71	15.95	31.4

KIS Reducing Tee Fabricated

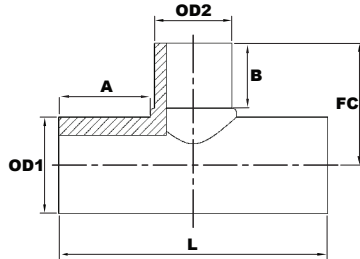

Feedstock DR	17	13.5	11	9
Pressure Rating	125 psi	160 psi	200 psi	250 psi
EDR	17	13.5	11	9

Product No.	Description	OD1 (in)	OD2 (in)	A (in)	B (in)	FC (in)	L (in)
40031117	3" X 2" DR 11 IPS REDUCING TEE FABBED	3.5	2.375	6.675	5.85	8.175	16
40041126	4" X 2" DR 11 IPS REDUCING TEE FABBED	4.5	2.375	6.675	5.85	8.675	16
40041127	4" X 3" DR 11 IPS REDUCING TEE FABBED	4.5	3.5	10	4.875	7.5	24
40061123	6" X 2" DR 11 IPS REDUCING TEE FABBED	6.625	2.375	6.675	5.85	9.7375	16
40061125	6" X 3" DR 11 IPS REDUCING TEE FABBED	6.625	3.5	10	4.875	8.8125	24
40061126	6" X 4" DR 11 IPS REDUCING TEE FABBED	6.625	4.5	9.5	4.8	8.9875	24
40081131	8" X 2" DR 11 IPS REDUCING TEE FABBED	8.625	2.375	6.675	5.85	10.7375	16
40081132	8" X 3" DR 11 IPS REDUCING TEE FABBED	8.625	3.5	10	4.875	9.8125	24
40081134	8" X 4" DR 11 IPS REDUCING TEE FABBED	8.625	4.5	9.5	4.8	10.2375	24
40081137	8" X 6" DR 11 IPS REDUCING TEE FABBED	8.625	6.625	10.3125	6.625	11.4125	28
40101133	10" X 2" DR 11 IPS REDUCING TEE FABBED	10.75	2.375	6.675	5.85	11.8	16
40101134	10" X 3" DR 11 IPS REDUCING TEE FABBED	10.75	3.5	10	4.875	10.875	24
40101135	10" X 4" DR 11 IPS REDUCING TEE FABBED	10.75	4.5	9.5	4.8	11.3	24
40101138	10" X 6" DR 11 IPS REDUCING TEE FABBED	10.75	6.625	10.3125	6.625	13.125	28
40101141	10" X 8" DR 11 IPS REDUCING TEE FABBED	10.75	8.625	10.375	6.575	13.575	30
40121142	12" X 2" DR 11 IPS REDUCING TEE FABBED	12.75	2.375	6.675	5.85	12.8	16
40121143	12" X 3" DR 11 IPS REDUCING TEE FABBED	12.75	3.5	10	4.875	11.875	24
40121144	12" X 4" DR 11 IPS REDUCING TEE FABBED	12.75	4.5	9.5	4.8	12.3	24
40121146	12" X 6" DR 11 IPS REDUCING TEE FABBED	12.75	6.625	10.3125	6.625	14.125	28
40121151	12" X 8" DR 11 IPS REDUCING TEE FABBED	12.75	8.625	10.3750	6.575	14.575	30
40121141	12" X 10" DR 11 IPS REDUCING TEE FABBED	12.75	10.75	9.25	6	12.875	30



KIS Molded Tees

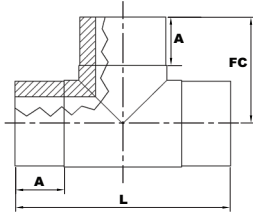

DR	17	11	9	7
Pressure Rating	125 psi	200 psi	250 psi	333 psi

Product No.	Description	OD (in)	A (in)	FC (in)	L (in)
50021119	2" DR 11 IPS TEE MOLDED	2.375	2.54	4.63	9.25
50031116	3" DR 11 IPS TEE MOLDED	3.5	3.19	5.88	11.83
50041123	4" DR 11 IPS TEE MOLDED	4.5	3.88	7.25	14.5
50061126	6" DR 11 IPS TEE MOLDED	6.625	5.5	9	18.13
50081125	8" DR 11 IPS TEE MOLDED	8.625	6.13	11.75	23.5
50101118	10" DR 11 IPS TEE MOLDED	10.75	6.44	13.38	26.75
50121118	12" DR 11 IPS TEE MOLDED	12.75	7.88	15.94	32.13

KIS Fabricated Tees

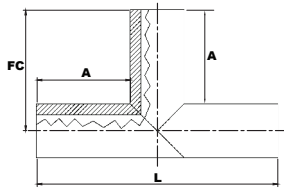

Feedstock DR	17	13.5	11	9	7
Pressure Rating	100 psi	125 psi	160 psi	200 psi	250 psi
EDR	21	17	13.5	11	9

Product No.	Description	OD (in)	A (in)	FC (in)	L (in)
40101130	10" DR 11 IPS TEE FAB HDPE EDR 13.5	10.75	6.5	11.875	23.75
40121137	12" DR 11 IPS TEE FAB HDPE EDR 13.5	12.75	8	14.375	28.75

*Larger sizes available upon request.

KIS Molded End Caps

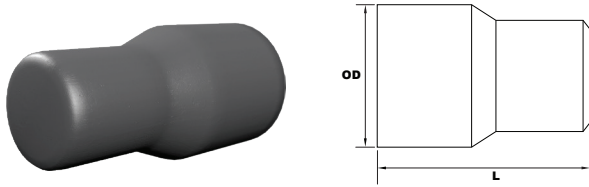

DR	17	11	9	7
Pressure Rating	125 psi	200 psi	250 psi	333 psi

Product No.	Description	OD (in)	L (in)
50021118	2" DR 11 IPS END CAP MOLDED HDPE	2.375	2.94
50031115	3" DR 11 IPS END CAP MOLDED HDPE	3.5	7.33
50041122	4" DR 11 IPS END CAP MOLDED HDPE	4.5	7.56
50061125	6" DR 11 IPS END CAP MOLDED HDPE	6.625	6.19
50081124	8" DR 11 IPS END CAP MOLDED HDPE	8.625	8
50101116	10" DR 11 IPS END CAP MOLDED HDPE	10.75	10.05
50121115	12" DR 11 IPS END CAP MOLDED HDPE	12.75	12.25

KIS Branch Saddles

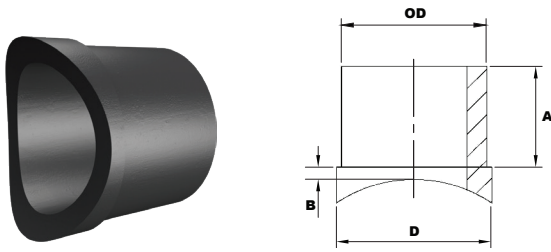

DR	17	11	9	7
Pressure Rating	125 psi	200 psi	250 psi	333 psi

Product No.	Description	OD (in)	A (in)	B (in)	D (in)
50031121	3"x2" DR11 IPS BRANCH SADDLE HDPE ROUND BASE	2.375	5.85	0.95	2.65
50041128	4"x2" DR11 IPS BRANCH SADDLE HDPE ROUND BASE	2.375	5.85	0.95	2.65
50061129	6"x2" DR11 IPS BRANCH SADDLE HDPE ROUND BASE	2.375	5.85	0.95	2.65
50081131	8"x2" DR11 IPS BRANCH SADDLE HDPE ROUND BASE	2.375	5.85	0.95	2.65
50101119	10"x2" DR11 IPS BRANCH SADDLE HDPE ROUND BASE	2.375	5.85	0.95	2.65
50121122	12"x2" DR11 IPS BRANCH SADDLE HDPE ROUND BASE	2.375	5.85	0.95	2.65
50041131	4"x3" DR11 IPS BRANCH SADDLE HDPE ROUND BASE	3.5	4.875	1	4
50061130	6"x3" DR11 IPS BRANCH SADDLE HDPE ROUND BASE	3.5	4.875	1	4
50081133	8"x3" DR11 IPS BRANCH SADDLE HDPE ROUND BASE	3.5	4.875	1	4
50101120	10"x3" DR11 IPS BRANCH SADDLE HDPE ROUND BASE	3.5	4.875	1	4
50121124	12"x3" DR11 IPS BRANCH SADDLE HDPE ROUND BASE	3.5	4.875	1	4

1. Any size (IPS/DIPS) main available, but must be larger than outlet size.
2. Hole saws for field cutting coupons are available for purchase.
3. Saddles are typically matched to the DR of the main. Thinner DR outlets may be available. Contact your ISCO representative for availability.



KIS Socket Fusion Fittings

Product No.	Description
52020031	2" X 2" X 2" IPS TEE SOCKET FUSION
52020011	2" IPS 90 DEG ELBOW SOCKET FUSION
52020014	2" CAP SOCKET FUSION
52020015	2" IPS COUPLING SOCKET FUSION
52031120	3" X 3" X 3" DR 11 IPS TEE BLACK SOCKET FUSION
52031118	3" DR 11 IPS 90 DEG ELBOW SOCKET FUSION BLACK
52031115	3" DR 11 IPS CAP SOCKET FUSION BLACK
52031119	3" DR 11 IPS COUPLING SOCKET FUSION BLACK

KIS Electrofusion Coupling

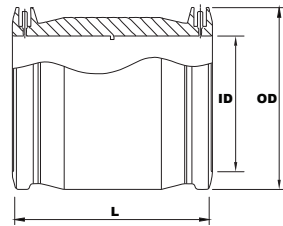

Product No.	Description	ID Max (in)	ID Min (in)	Coupling OD (in)	L (in)
56020012	2" IPS ELECTROFUSION COUPLING	2.42	2.395	3.78	4.72
56030012	3" IPS ELECTROFUSION COUPLING	3.56	3.545	5.18	5.59
56040015	4" IPS ELECTROFUSION COUPLING	4.545	4.51	6.51	6.14
56060016	6" IPS ELECTROFUSION COUPLING	6.69	6.655	8.7	8.35
56080014	8" IPS ELECTROFUSION COUPLING	8.7	8.67	11.2	9.48
56100014	10" IPS ELECTROFUSION COUPLING	10.801	10.766	13.41	10.5
56120014	12" IPS ELECTROFUSION COUPLING	12.795	12.74	15.84	11.5
56140011	14" IPS ELECTROFUSION COUPLING	14.01	13.98	17.24	12.13
56160011	16" IPS ELECTROFUSION COUPLING	16.01	15.98	19.65	13.54
56180011	18" IPS ELECTROFUSION COUPLING	18.01	17.98	22.13	14.96

1. Couplings are typically rated for water service up to 200 psi using DR 7-17 pipe.
2. For sizes above 24" contact your ISCO representative

KIS Transition Fitting HDPE to Male NPT Threaded Metal

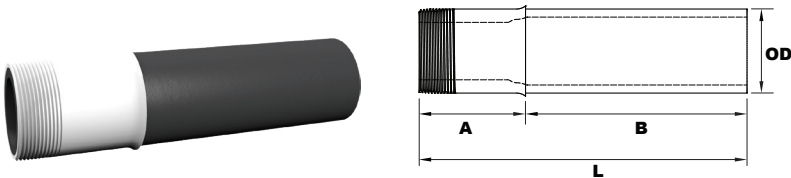

DR	17	11	9	7
Pressure Rating	125 psi	200 psi	250 psi	333 psi

Product No.	Description	OD (in)	A (in)	B (in)	L (in)
53021123	2" DR 11 IPS MPT TRANS FIT STAINLESS STEEL 304	2.375	3	5	8
53031121	3" DR 11 IPS MPT TRANS FIT STAINLESS STEEL 304	3.5	4	4	8
53041126	4" DR 11 IPS MPT TRANS FIT STAINLESS STEEL 304	4.5	4	8	12
53061124	6" DR 11 IPS MPT TRANS FIT STAINLESS STEEL 304	6.625	5	8	13
53081127	8" DR 11 IPS MPT TRANS FIT STAINLESS STEEL 304	8.625	7	8	15

1. Available in Brass, Carbon Steel (Epoxy Coated), 304 and 316 Stainless Steel
2. FPT threaded transitions are also available upon request.

KIS Transition Fitting HDPE to Plain End PVC

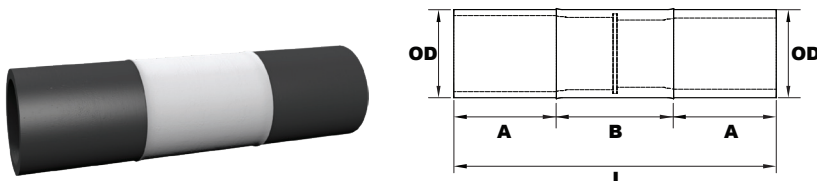

DR	17	11	9	7
Pressure Rating	125 psi	200 psi	250 psi	333 psi

Product No.	Description	OD (in)	A (in)	B (in)	L (in)
53030015	3" DR 11 IPS X PLAIN END SCH 80 PVC TRANS FITTING	3.5	5.5	5	16
53040010	4" DR 11 IPS X PLAIN END SCH 80 PVC TRANS FITTING	4.5	5	6	16
53060010	6" DR 11 IPS X PLAIN END SCH 80 PVC TRANS FITTING	6.625	9	8	26
53080068	8" DR 11 IPS X PLAIN END SCH 80 PVC TRANS FITTING	8.625	10.5	9	30

1. PVC available as Schedule 40 or Schedule 80.
2. Metal available as Carbon Steel (Epoxy Coated) or Stainless Steel.



KIS Specification Guide

SECTION 15XXX

HIGH DENSITY POLYETHYLENE (HDPE) PIPE, FITTINGS AND JOINING/FUSION

PART 1 – GENERAL

1.01 SCOPE OF WORK

A. This specification covers the material (pipe and fittings), joining methods, and general installation practice for high density polyethylene pipe (HDPE) piping systems for use as indicated on the Drawings.

1.02 SUBMITTALS

A. Submit product data to the Engineer for review in accordance with the Section XXXXX for all pipe, fittings, and appurtenances.

B. Contractor shall also submit the following to the Engineer for approval:

1. Certified dimensional as-built drawings/profile of all installed pipe, specials and fittings.
2. Details of fittings and specials such as elbows, tees, outlets, connections, test bulkheads, nozzles or other special items where shown on the Construction Drawings. All connections to jointed gasketed pipe materials, valves or fire hydrants must be restrained and supported independently to withstand the pressure transients, soil settlement, and external loading conditions.
3. The Supplier of the material shall submit, through the Contractor, a Certificate of Compliance that the HDPE pipe and fittings furnished for this project meet or exceed the standards set forth in this specification. The Contractor shall submit these certificates to the Engineer prior to installation of the pipe materials.

4. Provide a certification that personnel responsible for fusing the pipe have been trained and qualified per ASTM F3190

C. For items that do not meet all of the requirements of this specification, the bid/submittal shall include a written description of the deviations, along with data that show the magnitude and the justification for the deviation from the specification. The decision to accept material deviating from this specification shall be the responsibility of the specifying engineer and must be approved in writing.

1.03 REFERENCE DOCUMENTS AND STANDARDS

The standards and documents listed below may apply to the materials and practices in this specification. In the event of a conflict, the requirements of this specification prevail. Unless otherwise specified, references to documents shall mean the latest published edition of the referenced document in effect at the project bid date.

ANSI/AWWA

- ANSI/AWWA C901 Polyethylene (PE) Pressure Pipe and Tubing, 3/4 in. (19 mm) Through 3 In. (76 mm) for Water Service
- ANSI/AWWA C906 Polyethylene (PE) Pressure Pipe and Fittings, 4 in. Through 65 in. (100 mm Through 1,650 mm) for Waterworks
- ANSI/AWWA C651 Standard for Disinfecting Water Mains
- AWWA M55 Manual of Water Supply Practices, PE Pipe-Design and Installation

Plastics Pipe Institute, PPI

- PPI Handbook of Polyethylene Pipe – 2009 (2nd Edition)
- PPI Municipal Advisory Board (MAB) MAB-01 Generic Electrofusion Procedure for Field Joining of 12 Inch and Smaller Polyethylene (PE) Pipe
- PPI Material Handling Guide for HDPE Pipe and Fittings
- PPI TR-33 Generic Butt Fusion Joining Procedure for Field Joining of Polyethylene Pipe
- PPI TR-34 Disinfection of Newly Constructed Polyethylene Water Mains
- PPI TN-38 Polyethylene Flanged Joints
- PPI TR-41 Generic Saddle Fusion Joining Procedure for Polyethylene Gas Piping
- PPI TR-46 Guidelines for Use of Mini-Horizontal Directional Drilling for Placement of High Density Polyethylene Pipe

ASTM

- ASTM D2321 Standard Practice for Underground Installation of Thermoplastic Pipe for Sewers and Other Gravity-Flow Applications
- ASTM D2683 Standard Specification for Socket-Type Polyethylene Fittings for Outside Diameter- Controlled Polyethylene Pipe and Tubing
- ASTM D2774 Standard Practice for Underground Installation of Thermoplastic Pressure Piping
- ASTM F2880 Standard Specification for Lap-Joint Type Flange Adapters for Polyethylene Pressure Pipe in Nominal Pipe Sizes 3/4 in. to 65 in.
- ASTM D3035 Standard Specification for Polyethylene (PE) Plastic Pipe (DR-PR) Based on Controlled Outside Diameter
- ASTM D3261 Standard Specification for Butt Heat Fusion Polyethylene (PE) Plastic Fittings for Polyethylene (PE) Plastic Pipe and Tubing
- ASTM D3350 Standard Specification for Polyethylene Plastics Pipe and Fittings Materials
- ASTM F585 Standard Guide for Insertion of Flexible Polyethylene Pipe Into Existing Sewers
- ASTM F714 Standard Specification for Polyethylene (PE) Plastic Pipe (DR-PR) Based on Outside Diameter
- ASTM F1055 Standard Specification for Electrofusion Type Polyethylene Fittings for Outside Diameter Controlled Polyethylene and Crosslinked Polyethylene (PEX) Pipe and Tubing
- ASTM F1417 Standard Practice for Installation Acceptance of Plastic Non-pressure Sewer Lines Using Low-Pressure Air
- ASTM F1962 Standard Guide for Use of Maxi-Horizontal Directional Drilling for Placement of Polyethylene Pipe or Conduit under Obstacles, Including River Crossings
- ASTM F2164 Standard Practice for Field Leak Testing of Polyethylene (PE) and Crosslinked Polyethylene (PEX) Pressure Piping Systems Using Hydrostatic Pressure
- ASTM F2206 Standard Specification for Fabricated Fittings of Butt-Fused Polyethylene (PE)
- ASTM F2620 Standard Practice for Heat Fusion Joining of Polyethylene Pipe and Fittings
- ASTM F3124 Standard Practice for Data Recording the Procedure Used to Produce Heat Butt Fusion Joints in Plastic Piping Systems or Fittings
- ASTM F3183 Standard Practice for Guided Side Bend Evaluation of Polyethylene Pipe Butt Fusion Joint
- ASTM F3190 Standard Practice for Heat Fusion Equipment (HFE) Operator Qualification on Polyethylene (PE) and Polyamide (PA) Pipe and Fittings
- ASTM F1804 Standard Practice for Determining Allowable Tensile Load for Polyethylene (PE) Gas Pipe During Pull-In Installation
- ASTM B843 Standard Specification for Magnesium Alloy Anodes for Cathodic Protection

PART 2 – PRODUCTS**2.01 HIGH DENSITY POLYETHYLENE MATERIALS****A. Resin and Material Requirements**

1. All material shall be manufactured from a PE 4710 resin listed with the Plastic Pipe Institute (PPI) as TR-4. The resin material shall meet the specifications of ASTM D3350 with a minimum cell classification of 445474C or 445574C. HDPE pipe and fittings shall contain no recycled compounds except that generated in the manufacturer's own plant from resin of the same specification from the same raw material. HDPE products shall be homogeneous throughout and free of visible cracks, holes, foreign inclusions, voids, or other injurious defects.

B. HDPE Pipe

1. Pipe shall be made of HDPE material with a minimum material designation code of PE4710 and with a minimum Cell Classification as noted in 2.01.A. The polyethylene compound shall be suitably protected against degradation by ultraviolet light by means of carbon black of not less than 2 percent. The manufacturer of the HDPE resin shall certify the cell classification indicated.

2. Pipe sizes 3" DIPS/4" IPS and larger shall have a manufacturing standard of ASTM F714, while IPS pipe 3" and smaller shall be manufactured to the dimensional requirements listed in ASTM D3035. Dimension Ratio (DR) and Outside Diameter (IPS/DIPS) shall be as specified on plans.

3. Pipe shall be manufactured by an ISO 9001 certified manufacturer. The pipe manufacturer shall have an ongoing Quality Control program for incoming and outgoing materials, and shall assure that the pipe will meet the material requirements of this specification. HDPE resins for manufacturing of pipe shall be checked for density, melt flow rate, and contamination. For potable water systems the facility shall have the necessary testing equipment to verify that pipe meets the AWWA and NSF standards. Pipe shall be checked for outside diameter, wall thickness, length, and surface finish on the outside. The Manufacturer's production facilities shall be open for inspection by the Owner or Engineer.



4. All pipe may be color coded for the intended service. When required, the color coding shall be permanently co-extruded stripes on the pipe outside surface as part of the pipe's manufacturing process. Painting HDPE pipe to accomplish color coding is not permitted.

C. HDPE Fittings

1. Butt Fusion Fittings - Fittings shall be made of HDPE material with a minimum material designation code of PE4710 and with a minimum Cell Classification as noted in 2.01.A. Fittings shall have a minimum pressure rating equal to or greater than the pipe to which they are joined unless otherwise specified on the plans or accepted by owner/engineer.

a. Molded fittings shall comply with the requirements of ASTM D3261.

b. All fabricated elbows, tees, reducing tees and end caps shall be produced and meet the requirements of ASTM F2206, as manufactured by ISCO Industries, Inc or other approved manufacturer holding an ISO 9001 quality system certificate. Each fitting will be marked per ASTM F2206 section 10 including the nominal size and fitting EDR, which will meet or exceed the pipe DR identified for the project. For example, mitered fittings (elbows and tees) will be fabricated from DR 11 pipe for use in DR 13.5 systems. Fabricated fittings shall be manufactured using a data recording device to record fusion pressure and temperature, and shall be stamped with unique joint number that corresponds to the joint report. A graphic representation of the temperature and pressure data for all fusion joints made producing fittings shall be maintained for a minimum of 5 years as part of the quality control and will be available upon request of owner. Test results to validate ASTM F2206 section 7.3 and 9 shall be provided to owner or owner's representative upon request.

c. Socket fittings shall meet ASTM D2683.

2. Electrofusion Fittings - Fittings shall be made of HDPE material with a minimum material designation code of PE 4710 and with a minimum Cell Classification as noted in 2.01.A. Electrofusion Fittings shall have a manufacturing standard of ASTM F1055. Fittings shall have a minimum pressure rating equal to or greater than the pipe to which they are joined unless otherwise specified on the plans.

3. Bolted Connections - Flanged and Mechanical Joint Adapters or must be made to ASTM D3261. Flange adapters, if machined, must also meet the requirements of ASTM F2880. Flanges and MJ Adapters shall be fused onto the pipe and have a minimum pressure rating equal to or greater than the pipe unless otherwise specified on the plans.

a. Metallic back-up rings (Van-Stone style lap joint flanges), shall have a radius on the inside diameter of the bore so as to be compatible with HDPE Flanges. Back up rings shall have bolt pattern that will mate with AWWA C207 Class D (or B or E), ASME/ANSI B 16.5 Class 150, ASME/ANSI B 16.1 Class 125, or ASME/ANSI B16.47 Series A.

b. Flange assemblies shall be assembled and torqued according to PPI TN-38, " Polyethylene Flanged Joints."

c. Where shown on the drawings, 4" and larger transitions to mechanical joint fittings and valves shall be accomplished using a MJ Adapter with kit. The D.I./HDPE mechanical joint adaptor shall consist of:

- i. A molded or fabricated HDPE mechanical joint transition fitting.
- ii. A rubber gasket.
- iii. A mechanical joint gland ring.
- iv. Corten mechanical joint tee bolts.

4. Mechanical Fittings: The use of mechanical coupling and saddles shall be approved by the owner or engineer prior to installation. Mechanical Fittings shall be designed for use and compatible with HDPE pipe. Mechanical fittings shall have a pressure rating equal to or greater than the pipe.

a. Couplings without self-restraining capabilities (integrated serrated teeth or grippers) shall include a plan for external restraint or isolation from pipeline generated forces.

b. Mechanical Saddles shall have wide straps for distribution of clamping loads. No U- bolts shall be allowed.

c. When required by mechanical coupling manufacturer, pipe stiffeners shall be employed to support the interior wall of the HDPE. The stiffeners shall support the pipe's end and control the "necking down" reaction to the pressure applied during normal installation. The pipe stiffeners shall be formed of 304 or 316 stainless steel, with a wedged style design to fit the HDPE manufacturers published average inside diameter of the specific size and DR of the HDPE.

D. Fusion Unit Requirements

1. All Fusion Equipment, whether new or used, rented or owned, shall comply with the requirements of ISO 12176-1 "Equipment for Fusion Jointing Polyethylene Systems".
2. Butt fusion equipment must be in satisfactory working order and the hydraulic system must be leak free. Heater plates shall be free from scrapes or gouges and have a consistent, clean, coated surface. The pressure gauge and thermometer should be properly calibrated. When requested by the owner, records showing a maintenance service/inspection within 3 months prior to use for this project shall be provided.
3. Rental Butt Fusion Equipment must be maintained by a McElroy Authorized Service and Repair Center with at least one McElroy Certified Master Mechanic on staff. When requested by owner or his authority, an inspection report detailing the components inspected within 3 months prior to arrival at jobsite will be provided.
4. For 16" and larger pipe sizes, the butt fusion machine shall be capable of autonomously calculating the drag pressure and perform the shift sequence autonomously.
5. Electrofusion Processors shall be maintained and calibrated per manufacturer's requirements and recommendations.

E. Approved Suppliers

1. All Pipe, Fittings, and Fusion Equipment shall be provided by one supplier. Approved suppliers are ISCO Industries, Inc. or approved equal.

2.02 PIPELINE LOCATING MATERIALS

A. Detectable Marker Tape - Plastic marker tape shall be 5 mil minimum thickness with a solid aluminum core of .35mil minimum thickness and a minimum width of 2". The background of the tape shall be colored based on pipe service with black lettering continuously printed. Marker tape shall have a minimum 35 lbs./inch tensile strength. The installation of the tape shall be at 18 inches below finish grade.

B. Tracer Wire - All HDPE pipe 4" and greater shall be installed with an extra high-strength, copper clad steel tracer wire including 45 mil HDPE jacket that has a minimum average break load of at least 1150 lbs. The jacket shall be colored based on pipe service, with blue for potable water or green for sewer. Tracer wire gauge shall be 12 AWG, 10 AWG, or 8 AWG depending upon application and installation procedure. This wire shall to be continuous and brought up in the valve boxes at the ends of each line segment with splices made only by methods per the equipment manufacturer's recommendation. All miscellaneous splicing components shall be furnished and installed by the Contractor.

2.03 VALVES

A. Gate Valves shall be KIS AVK Series 66 with HDPE end connections, KIS AVK Series 45, or approved equal.

B. Ball Valves shall be KIS HDPE 360 Ball Valves or KIS HDPE Quarter Turn Ball Valves, or approved equal.

PART 3 – EXECUTION

3.01 GENERAL

A. All HDPE pipe and fittings shall be cut, joined, and installed in accordance with the manufacturer's recommendations. Joining, laying, and pulling of polyethylene pipe shall be accomplished by personnel experienced in working with polyethylene pipe systems.

3.02 TRANSPORTATION, UNLOADING, AND STORAGE

A. The manufacturer shall package product in a manner designed to deliver the pipe and fittings to the project neatly, intact and without physical damage. During transportation, each pipe shall rest on suitable pads, strips, skids, or blocks securely wedged or tied in place.

B. During loading, transportation, and unloading, every precaution should be taken to prevent damage to the pipe. The handling of the pipeline shall be in such a manner that the pipe is not damaged by dragging it over sharp and cutting objects. Cuts or gouges that reduce the wall thickness by more than 10% are not acceptable and must be cut out and discarded.

C. Handle the pipe in accordance with the PPI Handbook of Polyethylene Pipe (2nd Edition), Chapter 2. All pipe and accessories shall be loaded and unloaded by lifting with hoists or by skidding in order to avoid shock or damage. Under no circumstances shall materials be dropped. Pipe handled on skidways shall not be rolled or skidded against pipe on the ground. Slings, hooks, or pipe tongs shall be padded and used in such a manner as to prevent damage to the exterior surface or interior of the pipe. All pipe and fittings shall be subjected to visual inspection at time of delivery and before they are lowered into the trench to be laid.

D. Materials, if stored, shall be kept safe from damage and shall not be stacked higher than the limits recommended by the manufacturer. The bottom tiers shall be kept off the ground on timbers, rails, or concrete. Pipe shall not be stored close to heat sources. The contractor shall be responsible for all security, damage, and loss of pipe, excluding Acts of God.

E. The interior of the pipe as well as all sealing surfaces of mating components (i.e. flange faces) shall be kept free from dirt or foreign matter at all times. The open ends of all sections of joined and/or installed pipe (not in service) shall be plugged to prevent insects, animals, or foreign material from entering the pipe line or pipe section. The practice of stuffing cloth or paper in the open ends of the pipe will not be permitted. Use waterproof nightcaps to prevent the entrance of any type of natural precipitation into the pipe and secure to the pipe in such a manner that the wind cannot blow them loose. Where possible, the pipe shall be raised and supported at a suitable distance from the open end such that the open end will be below the level of the pipe at the point of support.

3.03 RECEIPT INSPECTION

A. All pipe and fittings shall be subjected to visual inspection at time of delivery and before they are installed or lowered into the trench to be laid. Defective, damaged, or unsound pipe will be rejected. Cuts, punctures, or gouges that penetrate or reduce the wall thickness by 10% or more are not acceptable and must be removed and discarded. Joints or fittings that do not conform to these specifications will be rejected and must be removed immediately by the Contractor.

3.04 FUSION AND JOINING

A. Fusion Joining Requirements:

1. All HDPE pipe shall be joined by the heat fusion process which produces homogeneous, sealed, leak-tight joints. Tie-ins between sections of HDPE pipe shall be made by butt fusion whenever possible.

2. Butt Fusion: The pipe shall be joined by the butt fusion procedure outlined in ASTM F2620 or PPI TR-33. All fusion joints shall be made in compliance with the pipe or fitting manufacturer's recommendations. Fusion joints shall be made by qualified fusion technicians per ASTM F3190. A record or certificate of training for the fusion operator must be provided that documents training to the fundamentals of ASTM F2620. Considerations should be given to and provisions made for adverse weather conditions, such as temperatures below freezing, precipitation, or wind, which is accepted by the owner/engineer. Fusion of pipe with similar OD but dissimilar wall thickness shall be governed by ISCO Fusion Manual and accepted industry practice, which prohibits fusions if wall thickness difference is greater than 26%. The use of a controlled cooling cycle procedure to reduce cooling time is acceptable only where testing demonstrates that acceptable joints are produced using the controlled cooling cycle procedure.

3. Electrofusion: Electrofusion joining shall be done in accordance with the manufacturer's recommended procedure. Other sources of electrofusion joining information are PPI TN 34 and PPI Municipal Advisory Board (MAB) Generic Electrofusion Procedure for Field Joining of 12 Inch and Smaller Polyethylene (PE) Pipe. The process of electrofusion requires an electric source, commonly called an electrofusion processor that has wire leads and a method to read electronically (by laser) or otherwise input the barcode of the fitting. The electrofusion processor must be capable of reading and storing the input parameters and the fusion results for later download to a record file. Qualification of the fusion technician shall be demonstrated by evidence of electrofusion training within the past year on the equipment to be utilized for this project.

B. Fusion Operators:

1. The employer of the fusion machine operator is responsible for the fusion joint quality of the fusion weld made by that individual. The employer is responsible for documenting all training and qualification records for that individual, including compliance to any code requirements for fusion/bonder operators.

2. All HDPE fusion equipment operators shall be qualified to the procedure used to perform pipe joining. Fusion equipment operators shall have current, formal training on all fusion equipment employed on the project. Training received more than two years prior to operation with no evidence of activity within the past 6 months shall not be considered current.

3. For Projects with at least 5,000 feet or with pipe larger than 24 inches, operators or their supervisor must have a current McElroy Fusion Training Certificate for the equipment to be used on the project.

4. When the fusion machine operator is employed by the HDPE pipe and fusion machine supplier, the supplier shall maintain an ISO 9001 Certified Quality Management System.

C. Butt Fusion Equipment:

1. For 6" and larger pipe sizes, the pipe butt fusion machine shall be a self-contained hydraulic fusion machine capable of butt fusing HDPE pipe. The carriage must be removable from the chassis for in-ditch use. The machine must be compatible with an electronic data recording device. Accessories will include all butt fusion inserts for the specified range of pipe sizes, a pyrometer kit for checking the surface temperature of the heater, extension cord of appropriate gauge (25' minimum), and hydraulic extension hoses (minimum of four). The butt fusion machine will be McElroy, or approved equivalent.

2. For 16" and larger pipe sizes, the butt fusion machine shall be capable of autonomously calculating the drag pressure and perform the shift sequence autonomously.

3. In areas where there may be insufficient space for layout of the entire length of fused pipe to be pulled-back, the Contractor shall utilize a continuous HDPE pipe fusion equipment such as a PolyHorse by McElroy or other means in order to fuse the length of pipe necessary for the installation.

D. Fusion Data Recording:

1. For 6" and larger pipe sizes, McElroy DataLogger or equivalent fusion data recorder shall be used to record all fusion welds on hydraulically operated fusion machines. The device shall be capable of meeting the requirements of ASTM F3124, "Standard Practice for Data Recording the Procedure used to Produce Heat Butt Fusion Joints in Plastic Piping Systems or Fittings". The device, or combination of devices, shall record the following variables of each fused joint:

- i. Heater surface temperature- immediately before inserting the heater plate, measure with a pyrometer and manually enter into the weld record.
- ii. Gauge pressure during the initial heat cycle
- iii. Gauge pressure and elapsed time during the heat-soak cycle
- iv. Heater removal (dwell) time
- v. Gauge pressure and elapsed time during the fusing/cool cycle
- vi. Drag pressure
- vii. Pipe diameter and wall thickness
- viii. Type of HDPE material (Specification and Classification) and manufacturer
- ix. Fusion Machine Identification

2. The device shall record the operator name and a unique operator ID number, along with the date and time of each weld.

3. Records showing the device is up to date on all required calibration should be available for presentation when requested.

4. All fusion welds should be traceable to the report (via operator and weld ID) with an indentation weld stamp or by permanent paint marker/pen next to fusion weld.

5. A weld location map may be requested, prior to commencement of work, by the owner or owner's representative.

E. Butt Fusion Examination and Testing:

1. Examinations

i. Visual: For pipe sections, examine the full exterior circumference for bead uniformity. After fusing the pipe section, review the interior bead. All beads should have visually acceptable bead formation as shown in Fig 4 and Appendix X2 of ASTM F2620. In addition, the following characteristics are expected:

- 1. There shall be no evidence of cracks or incomplete fusing
- 2. There shall be no evidence of captured objects (e.g., pipe shavings, facer ribbons) between bonded surfaces.
- 3. Variations in upset bead heights on opposite sides of the cleavage and around the circumference of fused pipe joints are acceptable.
- 4. The apex of the cleavage between the upset beads of the fused joint shall remain above the base material surface
- 5. Fused joints shall not display visible angular misalignment, and outside diameter mismatch shall be less than 10% of the nominal wall thickness
- 6. Fusion data record review that meet criteria of section 3.04.D.1 can be used as additional verification of visual indicators.



ii. Fusion Data Record Review

The fusion data record for each fused joint shall be compared to the approved fusion procedure. The reviewer shall verify the following:

1. That all data required by section 3.04.D.1 was recorded
2. Interfacial pressure was within the acceptable range
3. Heater surface temperature was within the acceptable range
4. Butt fusion pressure applied during the fusing/cool cycle was correctly calculated to include drag pressure, fell within the acceptable range for the applicable size, and agrees with the recorded hydraulic fusing pressure.
5. Butt fusing pressure was reduced to a value less than or equal to drag pressure at the beginning of the heat soak cycle.
6. Fusing machine was opened at the end of the heat soak cycle, the heater was removed, and the end were brought together at the fusion pressure within the acceptable time range
7. Cooling time at butt fusing pressure met the minimum time specified

iii. If the recorded data in section 3.04.D.1 is outside the limits of the acceptable range, the joint is unacceptable, and must be removed and replaced.

iv. Frequency. Records for test fusion joints should be reviewed immediately after the joint is completed. Fusion joints for jobsite fusions should be reviewed daily or before being covered with backfill.

2. Mechanical Tests

i. Contractor shall mechanically test the first fusion of each operator and each machine used on the project. Installation shall not continue until a fusion has passed the test. Additional mechanical tests are not required as long as long as the fusions are reviewed with the frequency specified in section 3.04.E.1.iv. Testing of fusion joints with no fusion data record review shall be at a frequency specified by the Owner or Engineer.

ii. The fusion shall be allowed to cool completely, then fusion test straps shall be cut out.

iii. All samples shall be labeled with operator information. Testing must be done at 73 degrees F plus or minus 5 degrees. The test temperature and sample size are critical to testing. Testing performed at cold or elevated temperatures may not give similar results to tests performed at ambient temperatures.

iv. Each pipe sample weld shall be subjected to testing at two locations 180 degrees apart from each other in the joint weld. All specimens shall be tested by one of the following methods:

1. Reverse Bend Tests are allowed for pipe sizes 4" IPS or smaller. The specimens shall be prepared and tested in accordance with ASTM F2620, Appendix X4.
2. Guided Side Bend Tests are allowed for all wall thicknesses of 1" or greater. The specimens shall be removed and tested in accordance with ASTM F3183.
3. Hydrostatic Burst Test is allowed for pipe sizes 2"-24". The specimen length should measure 6 times pipe diameter with the butt fusion joint in the center of the specimen. The specimen should be tested in a tank filled with water, and testing conditions monitored and recorded with computerized equipment. The specimen will be tested at 4 times pipe rated pressure for 5 minutes with no failure of joint allowed.

v. Results of any mechanical test should be documented. Information on the weld and operator should be transferred from the sample to the testing record.

3.05 INSTALLATION

A. Direct Burial

1. Buried HDPE pipe and fittings shall be installed per engineering drawings and ASTM D2774, ASTM D2321, and AWWA Manual of Water Supply Practices M55 Chapter 8. The Basic Installation identified in AWWA M55 Chapter 5 (page 46 of 2020 version) shall be considered acceptable design and installation conditions.

2. When moveable trench bracing such as trench boxes, moveable sheeting, shoring, or plates are used to support the sides of the trench, care shall be taken in placing and moving the boxes or supporting bracing to prevent movement of the pipe, or disturbance of the pipe bedding and the backfill. Trench boxes, moveable sheeting, shoring, or plates shall not be allowed to extend below top of the pipe. As trench boxes, moveable sheeting, shoring, or plates are moved, pipe bedding shall be placed to fill any voids created, and the backfill shall be re-compacted to provide uniform side support for the pipe.

3. Pipe embedment - Embedment material should be Class I, Class II, or Class III materials as defined by ASTM D2321 Section 6. The use of Class IV or Class V materials is not recommended, however, they may be used only with the evaluation and approval of the engineer at a demonstrated achievable compaction

4. Bedding: Pipe bedding shall be in conformance with ASTM D2321 Section 8. Compaction rates should be as specified in ASTM D2321. Deviations shall be approved by the engineer.

5. Haunching and backfill shall be as specified in ASTM D2321 Section 9 with Class I, II, or III materials. Compaction shall be in excess of 85% Proctor, providing a minimum modulus of 1000 psi or greater.

B. Pull-In Installation

1. Per ASTM F1804 and/or www.HDPEapp.com, the contractor shall determine and document the maximum proposed pull-in length and pull-in force for the pressure class and pipe diameter to be pulled into an open trench. Pull-in lengths will not exceed the maximum lengths for the class and diameter pipe. A commercially available load limiter (weak link) approved by the Engineer shall be used between the puller and the pipe.

2. Prior to pulling the pipeline, contractor shall place rollers or other approved devices beneath the pipe to avoid unnecessary damage and to reduce pipe drag.

3. Trenchless installations:

- i. For Horizontal Directional Drilling (HDD), refer to ASTM F1962, PPI TR-46, PPI PE Handbook (Chapter 12) and www.PPIBoreAid.com
- ii. For sliplining, refer to ASTM F585, PPI PE Handbook (Chapter 11) and www.HDPEapp.com
- iii. For pipe bursting, refer to PPI PE Handbook (Chapter 16)

C. Appurtenances

1. All appurtenances (tees, elbows, services, valves, air relief valves, fire hydrants, etc.), must be independently supported and shall not rely on the pipeline and its connections for this support. Excessive stresses may be encountered when appurtenances are inadequately supported.

2. Hydrant Assemblies shall be installed and field tested according to the requirements of AWWA M17.

3. Installation of Tracer Wire. When tracer wire is required, the Contractor shall install along the entire section of pipeline and along all service connections as listed below. The tracer wire shall be installed simultaneously with the polyethylene piping system. Tracer wire shall be installed by the Contractor once backfill has been placed and compacted to at least 12 inches above the top of the pipe and not more than 18 inches above the top of the pipe. Tracer wire shall be properly spliced at each end connection and each service connection. Care should be taken to adequately wrap and protect wire at all splice locations. No bare tracer wire shall be accepted. Provide Magnesium alloy anode for cathodic protection that conforms to the requirements of ASTM B843. Install tracer wire per local and manufacturer's requirements.

3.06 PIGGING, FLUSHING, CLEANING, AND DISINFECTING

A. All mains shall be pigged, cleaned and flushed to remove all dirt, sand, debris, and other foreign matter. The Contractor shall be responsible for developing a pigging and flushing plan to be submitted to the Engineer for approval prior to pigging and flushing.

B. Disinfection:

1. Cleaning and disinfecting of potable water systems shall be in accordance with AWWA C651 and AWWA M55 Chapter 10, and PPI Handbook of Polyethylene Pipe Chapter 2 (2nd Edition).

2. The liquid disinfection chemical solution should be limited to less than 12% active chlorine. The time-duration of the disinfection should not exceed 24 hours. Chlorine tablets or powders are not permitted.

3. Upon completion, the system should be thoroughly flushed with fresh water, and retested to verify the disinfectant chlorine level has been reduced to potable drinking water concentrations in all service water tubing and branch lateral pipes.

3.07 TESTING AND LEAKAGE

A. The contractor shall ensure testing can be accomplished in a safe manner, including protection of personnel, equipment, and public in the event of a failure during testing. The contractor shall restrain pipe, components, and test equipment as required. All pumps, valves, temporary connections, meters, gauges, and other measuring devices shall be furnished, installed, and operated by the Contractor, and all such equipment and devices and their installation shall be approved by the Owner's Engineer.

B. The pressure gauges or data recorders should be calibrated and sufficiently sized to provide mid-range data that result in easy reading and interpretation. Gauges shall be accurate to within 2% of full scale.

C. The test pressure may be up to 1.5 times the system design pressure, based on the lowest point in elevation in the test section. The contractor shall ensure that the designated test pressure does not exceed the maximum allowable test pressure specified by the manufacturer for any component in the test section.

D. Test pressures require consideration of thermal conditions. Polyethylene piping materials are typically pressure rated at 73°F (23°C) and PE piping at temperatures greater than 80°F (26°C) require reduced test pressures. (Note that higher pipe temperatures should consider both ambient temperatures and radiant solar heating of exposed black HDPE pipe) Guidance for elevated temperatures can be found in the appendix of Chapter 3 (Material Properties) of the PPI Handbook of PE Pipe.

E. Gravity Pipelines-The Contractor shall perform a low-pressure air test for gravity flow pipelines to the requirements and specifications of ASTM F1417. Warning: All pneumatic test, regardless of pressure, can be dangerous and safety procedures shall be identified, documented, approved by the owner and engineer, and followed.

F. Pressure Pipelines-Pressure testing shall be conducted in accordance with requirements and recommendations of ASTM F2164 (Field Leak Testing of Polyethylene Pressure Piping Systems Using Hydrostatic Pressure), AWWA M55 Chapter 9, and PPI Handbook of Polyethylene Pipe Chapter 2 (2nd Edition). Pneumatic (compressed air) leakage testing of HDPE pressure piping is prohibited for safety reasons.

1. The section of pipe to be tested shall be filled with potable or generally clean water (uncontaminated river/lake water) approved by the Owner/Engineer. While the system is being filled with water, air shall be carefully and completely exhausted.

2. The test procedure for HDPE pipe consists of two steps: 1) the initial phase or expansion phase and 2) the test phase. During the initial/expansion phase, sufficient make-up water shall be added hourly for 3 hours to return to the test pressure. During the test phase, the expansion phase pressure is reduced by 10 psi to test phase pressure and monitored for at least one hour (3 hours maximum).

3. Under no circumstances shall the total time under test exceed eight (8) hours. If the test is not completed due to leakage, equipment failure, or any other reason, depressurize the test section and permit the system to "relax" for eight (8) hours prior to the next testing sequence.

4. In accordance with section 9.8 of ASTM F2164, the pipe shall pass if the final pressure is within 5% of the test phase pressure for the testing period (3 hours maximum). If the test section fails this test, the Contractor shall repair or replace all defective materials and/or workmanship at no additional cost to the Owner.

G. All pressure and leakage testing shall be done in the presence of a representative of the Owner and Engineer.

END OF SECTION



KIS PROJECTS

Addenbrooke Park Lakewood, CO	Fort Walton Beach Golf Club Fort Walton Beach, FL	Metairie Country Club Metairie, LA	Rose Hill Plantation Bluffton, SC
Astor Creek Golf Club Port St Lucie, FL	Gatlinburg Golf Course Pigeon Forge, TN	Mountain Air Country Club Burnsville, NC	Sarasota Polo Club Sarasota, FL
Atlanta Country Club Atlanta, GA	Grand Cypress Orlando, FL	Naples National Naples, FL	Savannah Lakes Village McCormick, SC
Bartow Golf Club Bartow, FL	Grey Oaks Country Club Naples, FL	Oakbourne Country Club Lafayette, LA	Surf Club North Myrtle Beach, SC
Belle Meade Country Club Nashville, TN	Gulf Harbor Lee County, FL	Old Palm Golf Club Palm Beach Gardens, FL	Tampa Bay Golf & Tennis Club San Antonio, FL
Big Canoe Jasper, GA	Hillcrest Country Club Boise, ID	Panther National Palm Beach Gardens, FL	Terravita Golf and Country Club Scottsdale, AZ
Bonita Bay Club Naples Naples, FL	Inn at Saint John's Plymouth, MI	Paradise Point Golf Course Smithville, MO	The Wellman Club Johnsonville, SC
Broken Tee Golf Course Englewood, CO	Jefferson Landing Golf Club Jefferson, NC	Payne's Valley Hollister, MO	Timuquana Country Club Jacksonville, FL
Buffalo Run Golf Club Commerce City, CO	Kensington Park Golf and Country Club Naples, FL	PGA National West Palm Beach, FL	Titleist Performance Institute Oceanside, CA
Cabot Citrus Farms Brooksville, FL	Killearn Country Club Tallahassee, FL	Polo Club Delray Beach, FL	TPC River Highlands Cromwell, CT
Camden Country Club Camden, SC	Kingsway Desoto County, FL	Promontory Club Park City, UT	University of North Carolina Finley Course Chapel Hill, NC
Cattail Creek Golf Course Loveland, CO	Lake Nona Orlando, FL	Quail Creek Golf Club Green Valley, AZ	Wachesaw Plantation Murrells Inlet, SC
Cherokee Plantation Yemassee, SC	Longboat Key Golf Club Longboat Key, FL	Quixote Club Sumter, SC	Walnut Creek Country Club Goldsboro, NC
Coral Ridge Fort Lauderdale, FL	Lookout Mountain Golf Club Lookout Mountain, GA	River Run Country Club Davidson, NC	Waynesville Inn & Golf Club Waynesville, NC
Coosa Country Club Rome, GA	Mallard's Landing Golf Club Melbourne, FL	Riverside Club Ruskin, FL	Wellen Park Venice, FL
Dallas Country Club Dallas, TX		Roanoke Country Club Roanoke, VA	
Darmor Golf Club Columbus, TX			
El Conquistador Golf & Tennis Oro Valley, AZ			Woodlake Country Club Vass, NC

